

## Stratos® Eco 2405

High-Tech at an astonishingly favorable price

Superior Knick technology is now also available in powerful basic versions: The new Stratos® Eco series is suitable for use in almost any standard application. The reliable 4-wire devices for the measurement of pH values, conductivity, or dissolved oxygen are the result of a particularly efficient product development.

### Complete solutions for a broad range of applications

- simple industrial applications
- downstream applications
- water processing
- aeration of natural waters
- energy production
- boiler water
- cooling water
- salt spring
- seawater desalination
- mineral water
- regeneration of ion exchangers
- drinking water/well water
- reverse osmosis
- fish farming

### Dimension Drawings

See page 543.



## Warranty 3 years!

### Warranty

Defects occurring within 3 years from delivery date shall be remedied free of charge at our plant (carriage and insurance paid by sender).  
Sensors and accessories: 1 year

**Facts**

- easy installation; large terminal compartment, rear unit can be pre-assembled
- wall, post/pipe, or panel mounting
- application in hazardous locations (FM, CSA Class I Div 2)
- large, high-contrast display
- simple, intuitive operation
- optical alarm signaling by bright, red LED
- temperature indication either in °C or °F
- easy calibration using process medium
- second current output for temperature measurement
- two floating relay contacts
- Sensocheck® continuous sensor monitoring
- Sensoface® preventive maintenance indication
- automatic buffer recognition by Calimatic®
- VariPower® power supply for 20 to 253 V AC/DC
- display of concentration (conductivity)
- reset to factory settings possible
- 3-year warranty

	<b>4-Wire process analyzers of the Stratos® Eco Series</b>
<b>pH/ORP measurement</b>	Stratos® Eco 2405 pH
<b>Conductivity measurement with 2- or 4-electrode sensors</b>	Stratos® Eco 2405 Cond
<b>Conductivity measurement, with electrodeless sensors</b>	Stratos® Eco 2405 Condl
<b>Dissolved-oxygen measurement</b>	Stratos® Eco 2405 Oxy

# Process Analysis Systems

## Stratos® Eco

### Reliable Flexibility

#### Uncompromising quality

From the calibration timer to the automatic GainCheck® device self-test, from the red alarm LED to the SensoCheck® sensor monitoring feature: The Stratos® Eco models provide all the sophisticated functions of the proven Stratos® devices.

#### Allows world-wide operation

Just one version with integrated VariPower® broad-range power supply unit allows trouble-free operation with any supply voltage (20 to 253 V AC/DC) even with large fluctuations in the mains voltage.

#### Easy to operate

The self-explaining user interface ensures comfortable and intuitive handling. Measured values and temperature are displayed simultaneously on the large, high-contrast LC display; unit symbols are shown in plain text. International icons provide operating messages and signal unusual operating states. Mode indicators show the current operating mode.

#### Preventive maintenance indication with Sensoface®



Sensor measures reliably



Measured value still acceptable, sensor should be checked and replaced, if required



Unreliable measurement, replace sensor

#### Cost-saving

The circuit technology, unrivalled by other manufacturers, means fewer electronic components and reduced energy consumption. These advantages give rise to an MTBF value of 110 years – plus the unusually long warranty period of 3 years. Thus, Stratos® Eco represents outstanding availability and extraordinary reliability.

#### Robust and safe

- robust PBT enclosure
- IP 65 protection
- suitable for rigid metallic conduits
- Ex classification Class I Div 2



### Simple to Install

The very flat and fully encapsulated electronics is integrated in the enclosure front. This has made ample room for cabling within the device and all parts are easy to access.



Like other Stratos® products, the *Eco* series also offers the option of wall, pipe/post, and panel installation. The installation is simplified by screw terminals and the pre-mountable plastic housing made from robust PBT.



Cable glands:  
M20 x 1.5 and NPT 1/2" or  
rigid metallic conduit

# Process Analysis Systems

## Stratos® Eco 2405

### Mounting Examples

#### ZU 0274 pipe-mount kit

For mounting on vertical or horizontal posts or pipes.

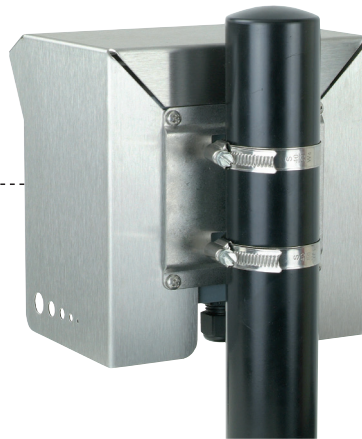

#### ZU 0276 protective hood

Additional protection from direct weather exposure and mechanical damage.



#### ZU 0275 panel mounting kit

For mounting in standardized panel cutout 138 x 138 mm (DIN 43700), sealed against panel.



**Dimension Drawings**

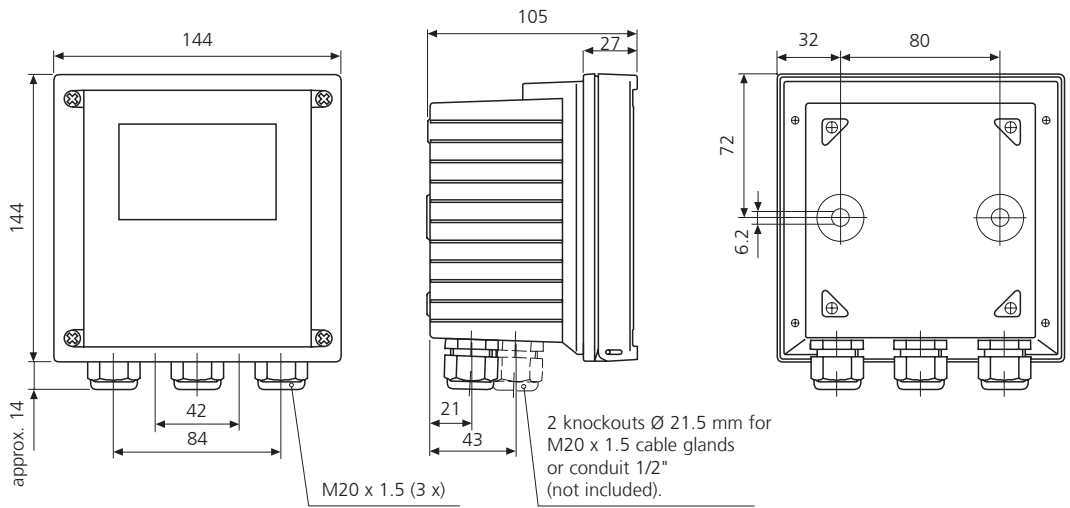

**ZU 0274 pipe-mount kit**  
consisting of:

- 1 Self-tapping screw (4 x)
- 2 Pipe-mount plate (1 x)
- 3 Hose clamps with worm gear drive DIN 3017 (2 x)

Optional for vertical or horizontal posts or pipes.

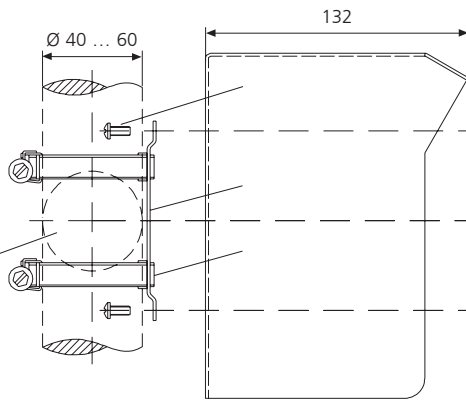

**ZU 0276 protective hood**

**ZU 0275 panel mounting kit**

