



# Mar4D PLQ 4200 Cylindrical coordinate measuring machines with multisensor system



Mar4D PLQ 4200

# Exactly the right machine for production

---

Customers expect a powerful and flexible measuring solution that covers a particularly broad range of dimensional measuring tasks for their often highly complex rotationally symmetrical workpieces. This is why the demand for machines with multisensor systems including contactless technology is steadily growing. This machine type should be sturdy enough to allow for 3D measurements either close to production or – better still – directly in production, including shorter throughput times and thus increased throughput. And lastly, besides their exceptional productivity, these

machines must meet the highest requirements in terms of precision and speed.

With its cylinder coordinate measuring machines from the Mar4D PLQ 4200 product line, Mahr offers its customers exactly this kind of complete package. This is a machine platform that Mahr has completely redeveloped with state-of-the-art technology and ergonomics to ensure that it is future-proof. The customer can select whatever features best suit his measuring requirements.

## Users benefit from the following advantages:

- Sturdy construction for close-to-production use
- Future-proof thanks to state-of-the-art technology
- Exceptional speed
- Maximum productivity
- Maximum precision
- Ergonomic operation
- Unique safety concept

# Contents

## Mar4D PLQ 4200

Universal 3D metrology for rotationally symmetrical workpieces



Product | Page 4

**Combined technologies** for numerous measuring tasks

Info | Page 6

**Ideal for many industries**

Info | Page 8

**Comprehensive performance range** in dimensional metrology

Info | Page 10

**Software**

Info | Page 12

**Technical data**

Info | Page 14

**Accessories**

Accessories | Page 16

# Universal 3D metrology for rotationally symmetrical workpieces

The machines from the new Mar4D PLQ 4200 product line allow you to efficiently perform a maximum of complex measuring tasks in one unique system. Depending on the machine type, up to five configurable CNC-axes offer maximum flexibility. A specially developed control architecture ensures that these axes move at an unrivaled speed. It's a win-win for you: In just one measuring run you can check several features at once such as length, diameter, form, position, contour, roundness, roughness or 3D geometries such as symmetry – in the shortest time at that. The integrated, tried and tested MarWin software will then evaluate the collected measuring data exactly according to your needs.

- Multisensor system with combined measuring technology: optical and tactile solution in one machine
- One setup – multiple measurements
- Optimal axis accuracy even with small tolerances
- For workpieces of up to 200 mm in diameter, 1000 mm in length and up to 50 kg in weight
- Sturdy machine construction for harsh production environments
- Environmental controls in the machine for precise and reliable measuring results
- Special safety concept with e. g. light grid

C-axis with  
**120 rpm**  
positioning and  
measuring speed

## Ergonomic design

The sophisticated design of the machine guarantees easy and safe operation.

## Versatile

Thanks to multisensor technology, the Mar4D PLQ 4200 can measure various rotationally symmetrical workpieces directly in production.

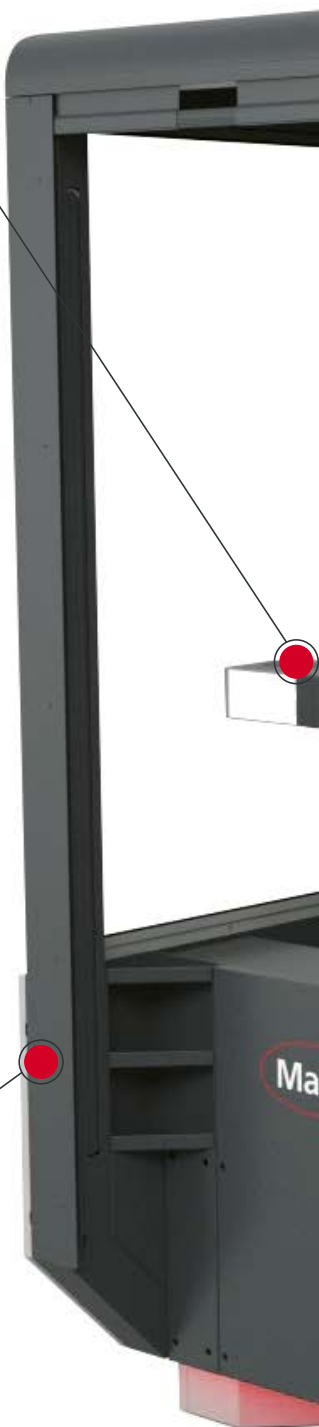



### Fast alignment

The motorized tailstock with clamping force monitor secures the workpieces perfectly without operator intervention.

### Process reliability when measuring

Monitoring systems in the machine record and compensate for external influences in real time, such as temperature and vibrations.

Measuring range up to

**200** mm

Diameter

up to

**50** kg

Workpiece weight

### Reliable software

The clearly structured user interface makes the MarWin software platform very user friendly: learn once, apply again and again.

up to

**1,000** mm

Workpiece length

## Combined technologies for numerous measuring tasks

Mahr has developed the machines in the Mar4D PLQ 4200 product line to the latest criteria and fitted them with sophisticated measuring technologies. This concept will take the testing of your rotationally symmetrical workpieces in production to a new level. Benefit from the following advantages:



### Speed

Measuring processes in production should be above all fast. A new **control architecture** in the Mar4D PLQ 4200 therefore ensures that the axes move at an unrivaled pace, for example the C-axis moves at 120 rpm. The built-in sensors also guarantee fast measurements: For example, the state-of-the-art, high resolution **matrix camera** records measuring data optically at maximum speed. The tactile probes – Mahr T7W for form, Renishaw SP25 for 3D features – also boast impressive speed. And lastly, the user-friendly MarWin software platform evaluates all measuring data reliably and according to your needs. Thus in just one setup, the user can perform multiple measurements at the same time, which also makes testing and consequently reliable quality readings much quicker.



### Productivity

An investment in the Mar4D PLQ 4200 is long term and future-proof. The machine saves costs, time and space in production as it offers **up to five measuring functions** in one unit: Our customers can replace up to five different measuring systems with this one machine. In addition, thanks to its **multisensor system**, the Mar4D PLQ 4200 can handle a multitude of different measuring tasks including inner measurement with the utmost flexibility, speed and precision. Rotationally symmetrical workpieces of up to 200 mm in diameter, 1,000 mm in length and 50 kg in weight can also be tested. Overall, users will increase their measuring capacities while reducing waiting times. Furthermore, there is significantly less waste as multiple integrated environmental controls ensure reliably consistent measuring conditions.



### Precision

The Mar4D PLQ 4200 guarantees precise measuring results and reliable repeatability. For example, integrated **environmental controls** e.g. for temperature and vibrations in real time reduce or even completely negate external influences on the measuring results. Furthermore, a **motorized tailstock** with configurable clamping force monitor minimizes user intervention and thus influences, thereby increasing accuracy. The measuring technologies also operate with maximum precision: the modern high-resolution matrix camera and the widely tested tactile Mahr T7W probe for form and Renishaw SP25 for 3D features. Lastly, the tried and tested MarWin software reliably evaluates the measuring data thus ensuring a reproducible quality reading.



### User-friendliness

Ergonomics and reliability were at the center of the Mar4D PLQ 4200 development; both have been realized far above the market standard. For example, a large **machine layout** allows convenient loading and unloading, even by smaller people. Using a so-called manipulator can make the machine especially labor-saving and ergonomic. Many of the processes are automated, for example clamping, aligning, measuring. Moreover, the Mar4D PLQ 4200 is **robot-ready**, i.e. prepared for automatic loading by robot. Interior monitoring protects the system and prevents service calls. The light grid in front of the loading space and functional LEDs indicating the status of the measurement ensure the safety of the operator and the machine.



## Ideal for many industries

The Mar4D PLQ 4200 cylinder coordinate measuring machines mean that you are perfectly equipped for testing your rotationally symmetrical workpieces quickly, precisely and reliably. Thanks to the integrated multisensor system, you can find the right solution even for the highest level of complexity.

The following industries in particular will benefit from the performance of the Mar4D PLQ 4200:



**Mechanical engineering and tool technology**



**Automotive industry**



**E-mobility**



**Renewable energies**





**Aerospace**



**Steel industry**

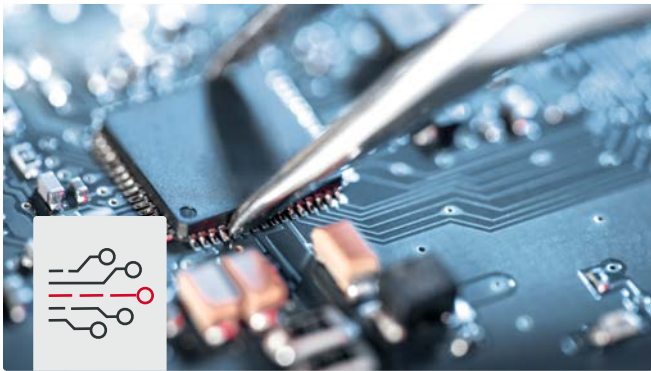

**Electronics**



**Medical technology**

# Comprehensive performance range in dimensional metrology

The Mar4D PLQ 4200 offers you a universal machine for your production. because it allows you to measure all the required features of your rotationally symmetrical workpieces, for example length, diameter, form, position, contour, roundness, roughness or 3D geometries such as symmetry – even several at once in just one measuring run.

Our sample workpiece demonstrates the main measuring features included in the performance range of the Mar4D PLQ 4200.



## Symbols for measuring characteristics and their meaning

	<b>Straightness</b>		<b>Roundness</b>   circular form
	<b>Cylindricity</b>   cylinder shape		<b>Line profile</b>   profile of any line
	<b>Simple runout</b>   radial run-out axial runout		<b>Inclination</b>
	<b>Position</b>   location		<b>Symmetry</b>
	<b>Surface roughness</b>		<b>Diameter</b>
	<b>Radius</b>		<b>Distance   Length</b>

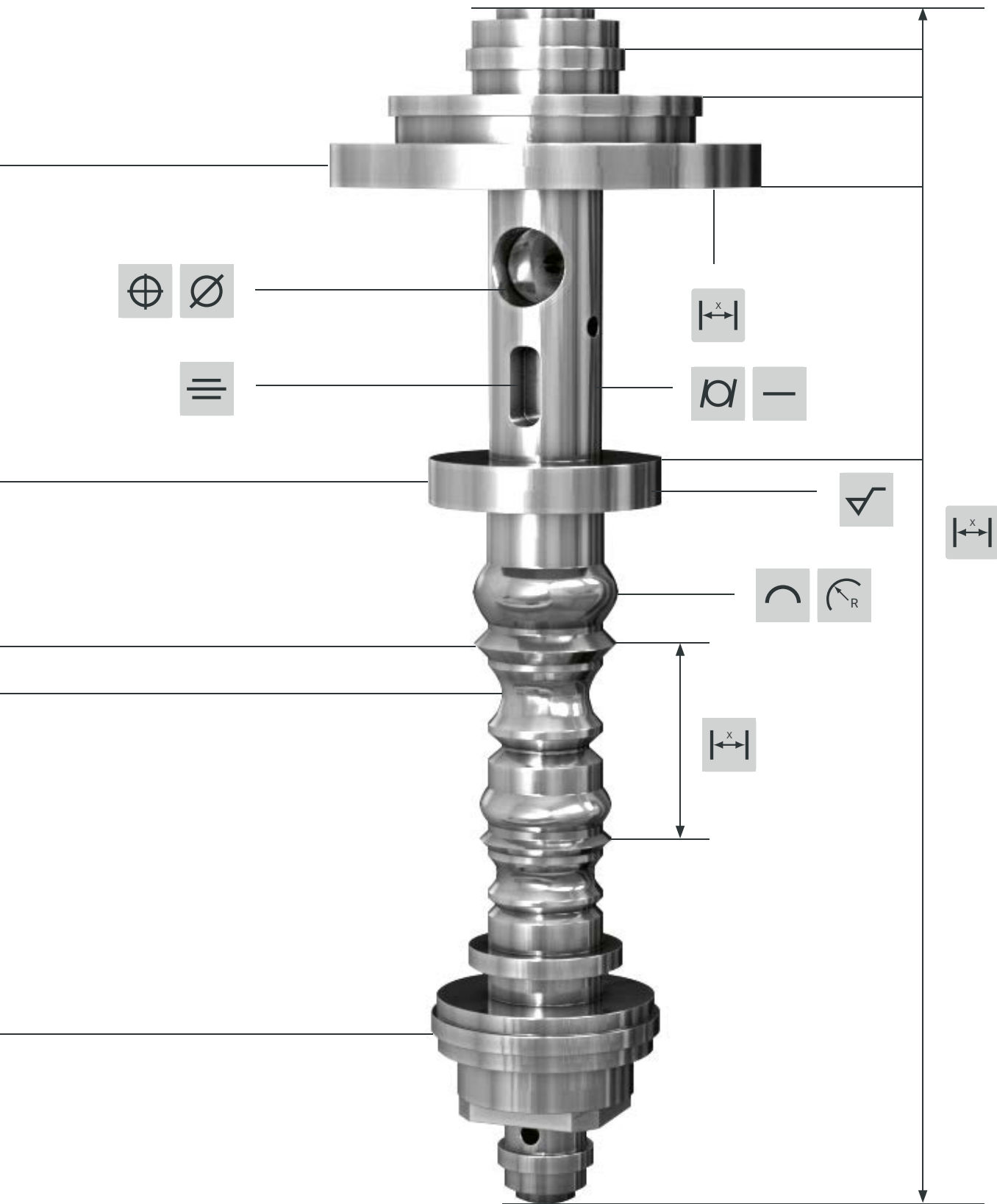

## Optimum support for your measuring tasks

The Mar4D PLQ 4200 from Mahr not only provides innovative hardware for dimensional measuring tasks but also supplies just the right measurement and evaluation software with the certified MarWin platform. It has established itself in more than sixty countries and is used by many Mahr reference customers. From fast individual measurement to complete series measurement, the platform offers important tools to make quality assurance more efficient and economical. This makes it ideal for manufacturing companies in Industry 4.0, where measurements and tests are becoming increasingly automated, networked and intelligent.

### User-guided measuring sequences

MarWin takes the user quickly and reliably through user-guided measuring sequences and configurable measuring records to the clear measuring result. The software offers intuitive, cascaded user guidance at easy, advanced or professional level or complete measuring programs. Extensive options for data analysis and processing complete the range of performance. Various software and hardware interfaces allow the MarWin measuring system to be integrated into the respective (data) environment.

### Learn once – apply again and again

The modular structure and consistent measuring language mean that measuring tasks can be performed across products. On the one hand this means that less training is required, and on the other it reduces the cycle time in the testing process. Users will also be able to meet future metrology requirements through license upgrades, software upgrades, software support agreements and individual software training. Mahr's measuring experts can help here if required. This makes the measuring system future-proof, because users maintain full control of the measurements, the measuring station and ultimately the quality of their products.





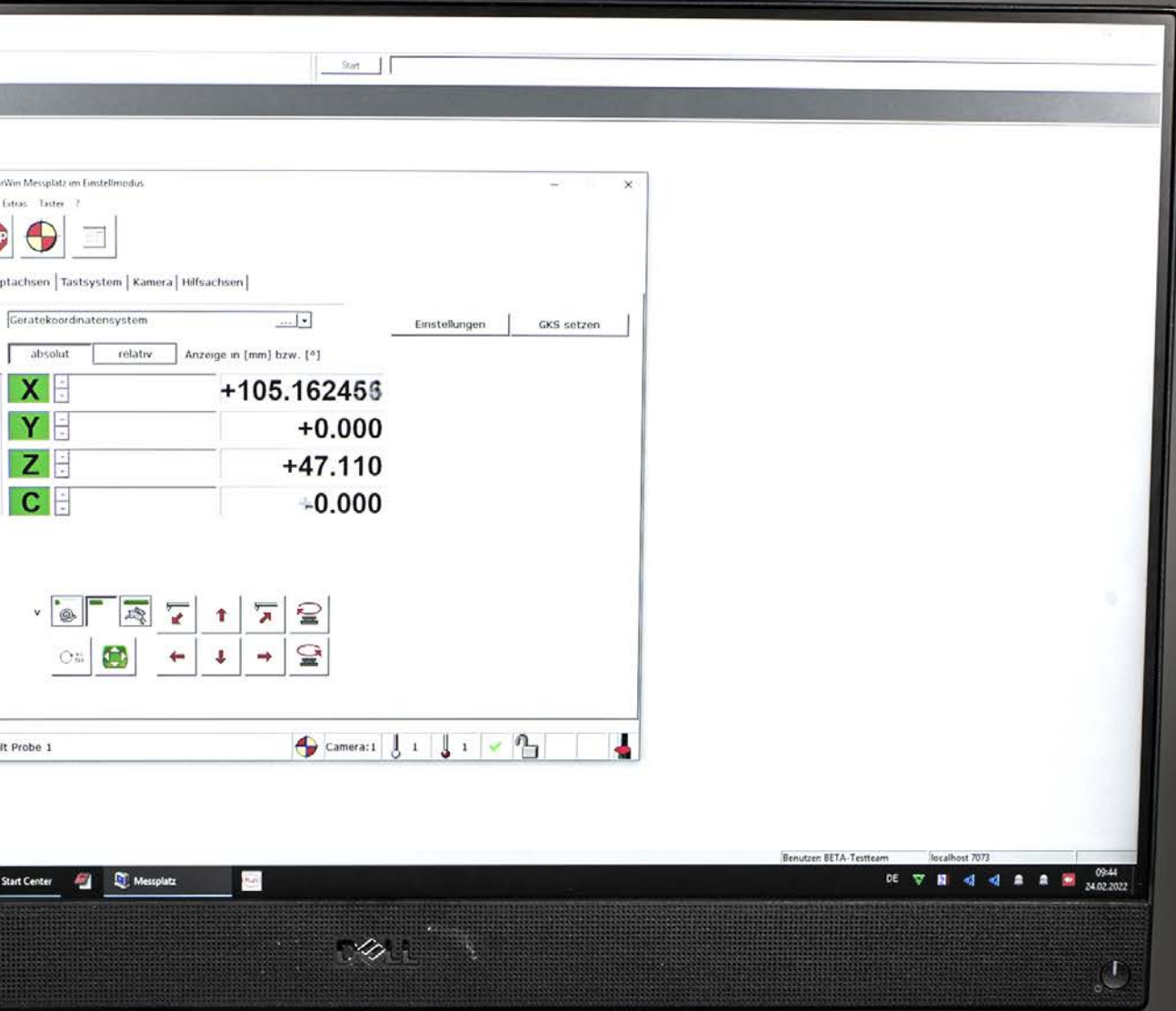

## Machine information

# Mar4D PLQ 4200-T2

Item no. 5554200 | Z = 450 mm, Item no. 5554201 | Z = 730 mm, Item no. 5554202 | Z = 1,000 mm

Item no.	5554200	5554201	5554202
Dimensions (W x H x D)	800 x 2,200 x 1,800 mm	800 x 2,500 x 1,800 mm	800 x 2,500 x 1,800 mm
Weight	ca. 1,100 kg	ca. 1,200 kg	ca. 1,300 kg
Measuring range (Z)	450 mm	730 mm	1,000 mm
Workpiece weight	max. 20 kg (optional 50 kg)		
Workpiece dimensions (max. length)	450 mm	730 mm	1,000 mm
Measurement resolution (lengths/diameters)	0.01 mm – 0.0001 mm 0.001 inch – 0.0001 inch		
Measurement resolution (angle)	0.01 – 0.0001°		
Error limits (parallel length measurement deviation, diameter only, EBXZ, MPE*)	$\leq (1 + l/150) \mu\text{m}$ (l in mm)		
Error limits (parallel length measurement deviation, length only parallel Z, EBXZ, MPE*)	$\leq (2 + l/200) \mu\text{m}$ (l in mm)		

\*Tempered workpiece at  $t=20 \pm 2^\circ\text{C}$ , on smooth surfaces ( $R_z < 1 \mu\text{m}$ ) DIN EN ISO 10360-7



<b>Drives</b>	
Travel speed Z	max. 200 mm/s
Travel speed X1	max. 200 mm/s
Travel speed X2	max. 50 mm/s
Rotational speed C	max. 120 1/min
Travel speed Y	max. 50 mm/s
Motorized travel speed Tailstock	max. 33 mm/s
<b>Optics</b>	Telecentric precision lens; green lighting with greater light output in flash mode, image field approx. 15 x 10 mm W/H
<b>Camera</b>	CMOS matrix with USB port, filter algorithm to exclude dirt particles
<b>Measuring computer</b>	Standard panel PC Windows 10 IOT LTSC Industry panel PC (optional)
<b>Ambient conditions</b>	
Operating temperature	+ 10 °C – + 40 °C
Recommended working temperature	+ 15 °C – + 35 °C
Storage/transport temperature	- 10 °C – + 50 °C
Permitted humidity	max. 90 % (non-condensing)
Temporal temperature gradient	< 1 K/h
Spatial temperature gradient	< 1 K/h ceiling height
Air pressure	1,000 hPa ± 200 hPa
Permitted ambient sound pressure	< 75 dB(A)
<b>Electrical connection</b>	
Supply voltage U~	90 – 240 V
Mains frequency	50/60 Hz
Power consumption	max. 850 VA
<b>Emitted sound level</b>	< 70 dB(A)

# Useful additions for every measuring task

Mahr offers an extensive portfolio of special accessories for the Mar4D PLQ 4200. These will expand your application options and provide even greater flexibility in adjusting the machines to your individual requirements.

## Probes and probe sets

Depending on the measuring task and workpiece, you can flexibly choose between various probes and probe sets to achieve the optimal measuring result.

Order no.	Description	Type
5550400	Tactile form probe, motorized	T7W
5400211	Probe set	T7W
5550250	Tactile 3D Renishaw probe	SP25M
5550251	Probe set 1 for SP25	–
5550252	Probe set 2 for SP25	–



## Centering tips

Centering tips are used to hold workpieces manufactured between tips precisely in the Mar4D PLQ 4200. The workpiece is synchronized by a clamping force of the tailstock which can be adjusted by software. The workpieces are often centered according to e.g. DIN 332 or ISO 6411. Inner cone angles are usually 60°. Depending on the size of the workpiece you can select: Mahr standard centering tips for clamping diameters from 2 mm to 44 mm. Hollow tips are used to clamp workpieces without centers.

Order no.	Description	Clamping diameter	Height
5361112	Centering tip 60°	Ø 2 – 15 mm	35 mm
5361223	Centering tip 60°	Ø 2 – 44 mm	46 mm
5361105	Centering tip 60°	Ø 3 – 15 mm	25 mm
5361106	Centering tip 60°	Ø 2 – 19 mm	44 mm
9056631	Centering tip 60°, coated	Ø 2 – 35 mm	46 mm
5361104	Hollow tip 90°	Ø 6 – 20 mm	30 mm
5361107	120° hollow tip, slotted for measurement in transmitted light process	Ø 8 – 40 mm	30 mm

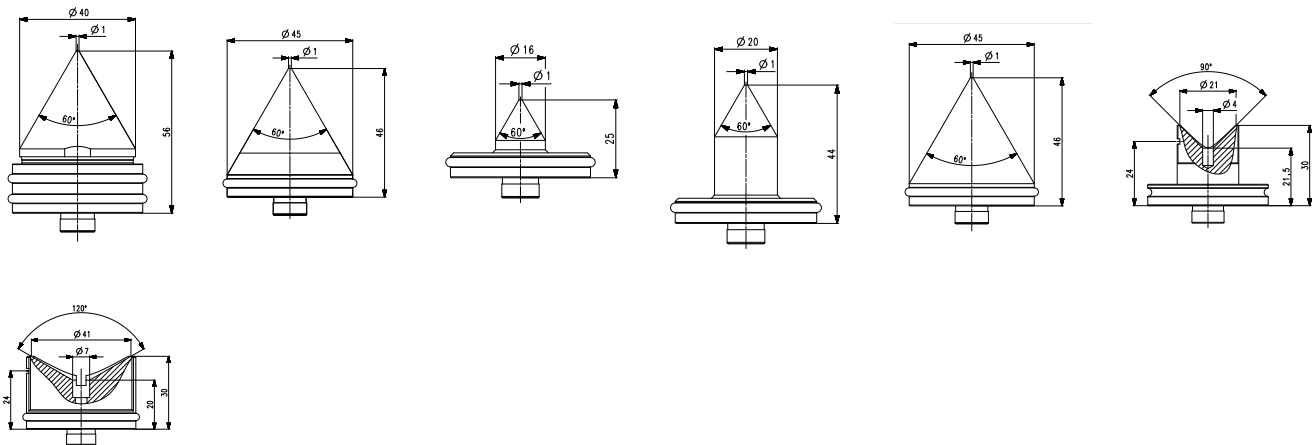

## Vibration isolation

There is an optional passive, controlled vibration isolation system available that can be integrated in the Mar4D PLQ 4200. It absorbs very strong ground vibrations at the installation site.

Order no.	Description
5550091	Passive, controlled vibration isolation system

## Housing-plus package

The housing-plus package allows you to add user-friendly options to the Mar4D PLQ 4200 which make operation even more reliable and convenient. These include signal lights on the roof indicating the status of the machine, additional lighting elements or a floor covering.

Order no.	Description
5550080	Housing-plus package

## Software

Thanks to the MarWin software platform the Mar4D PLQ 4200 offers user-friendly operation, and measurements can be programmed individually. The following package/options are available:

Order no.	Description	Type
5550100	MarWin complete package	Mar4D PLQ
5550460	T7W roughness measurement option for Mar4D PLQ 4200	–
5480638	Roughness option for AdvancedForm	–

## Hardware

Mahr also offers the relevant hardware for individually upgrading or converting the Mar4D PLQ 4200.



Order no.	Description
5550083	MarControl manual control panel
5550084	Industrial PC
5550085	Second monitor plus bracket
5550086	Panel PC included with measuring station
3026166	USB keyboard, German
3026167	USB keyboard, English

# Calibration

The quality of the finished workpieces ultimately depends on their dimensional accuracy. Calibration is therefore recommended, i.e. intensive testing together with traceability to (inter-) nationally recognized standards. Mahr offers the following accessories in this respect:

Order no.	Description
5360531	Calibrating shaft: Ø 25 – 110 mm, 583 mm long
5360581	Patented 3D contour standard (without calibration certificate)
9964316	Mahr calibration certificate for contour standard
6980110	DAKs/DKD calibration for contour standard
7024063	Reference wave

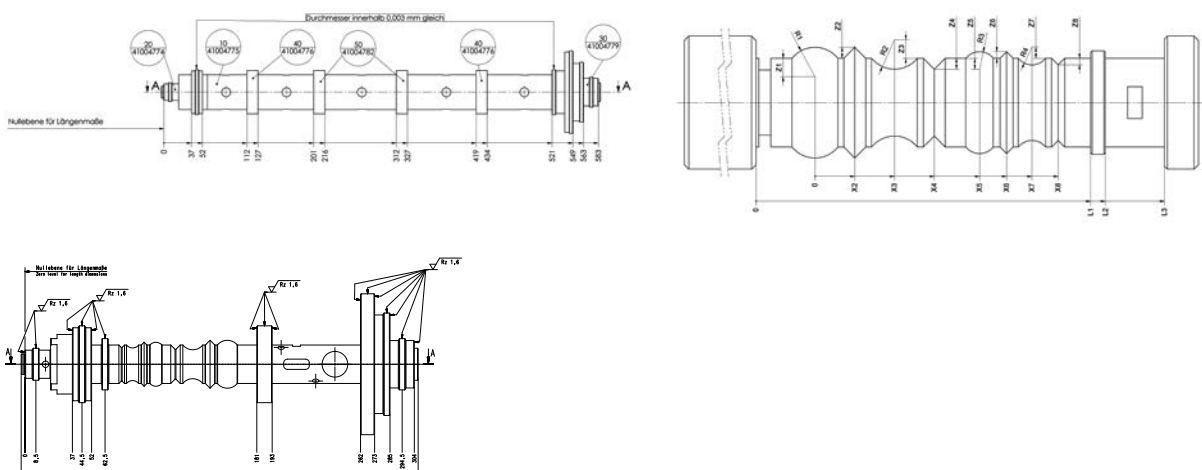

**Online**  
information

For more information,  
please visit our website.



**Mahr** GmbH  
Carl-Mahr-Straße 1  
37073 Göttingen  
Germany

Phone: +49 551 7073 800  
[info@mahr.com](mailto:info@mahr.com)  
[www.mahr.com](http://www.mahr.com)

© **Mahr** GmbH

We reserve the right to make changes to our products,  
especially due to technical improvements and further developments.  
All illustrations, numerical values, etc. are therefore subject to change.

3765862 | 04.2022