

LR3000

LR0000B-BR34AMPKG/US

Level sensors

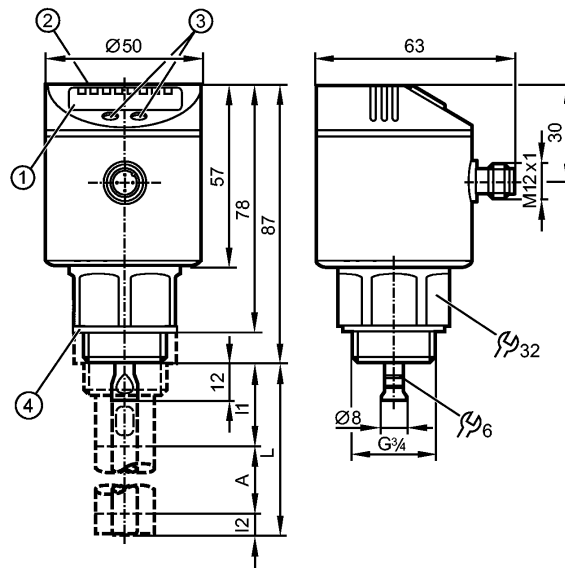

- 1: 4-digit alphanumeric display
- 2: LEDs (display unit / switching status)
- 3: Programming buttons
- 4: sealing
- A: Active range
- I1 / I2: Inactive ranges



Made in Germany

Product characteristics

Electronic level sensor
Connector
Process connection: G 3/4 A
Communication interface: IO-Link 1.1 (COM2 slave, 38.4 kBaud)
Guided wave radar
Freely rotatable housing 360°
Probe length: L = 100...1600 mm
2 outputs OUT1 = switching output OUT2 = analogue output
4-digit alphanumeric display

Application

Application	Hydrous coolants, oils, oil-based media, water, media similar to water
Cannot be used for:	fats, granulates, bulk materials, acids, alkalis; hygienic and electroplating applications; heavily foaming media
Medium temperature [°C]	0...80 (90 < 1 h)
Maximum speed of the change of level [mm/s]	100
Dielectric constant medium	≥ 2 for media with a dielectric constant 2...20 (e.g. oils) a coaxial pipe is required for operation (see below: accessories (optional))

Electrical data

Electrical design	DC PNP
Operating voltage [V]	18...30 DC
Current consumption [mA]	< 80
Protection class	III

LR3000

LR0000B-BR34AMPKG/US

Level sensors

Reverse polarity protection		yes
Outputs		
Output		2 outputs OUT1 = switching output OUT2 = analogue output
Output function		normally open / closed programmable; 4...20 mA or 0...10 V
Current rating	[mA]	200
Voltage drop	[V]	< 2.5
Short-circuit protection		thermal, pulsed
Overload protection		yes
Analogue output		I: 4...20 mA / U: 0...10 V
Max. load	[Ω]	I: 500
Min. load	[Ω]	U: 2000
Measuring / setting range		
Probe length L	[mm]	100...1600
Active range A	[mm]	L-40 (L-60)*
Inactive range I1 / I2	[mm]	30 / 10 (30)*
Setting range		
Set point, SP	[mm]	≥ 15 (35)* / ≤ L-30
Reset point, rP	[mm]	≥ 10 (30)* / ≤ L-35
in steps of	[mm]	5
Hysteresis	[mm]	≥ 5
Accuracy / deviations		
Deviations (in mm)		
Switch point accuracy		± (15 + 0.5 % MEW**)
Repeatability		± 5
Characteristics deviation		± 10
Offset error	[mm]	± 10
Measuring sensitivity		16 mA ÷ MEW** 10 V ÷ MEW**
Resolution	[mm]	0.5 (L < 300 mm) 0.2% MEW** (L > 300 mm)
Zero signal [mA] / [V]		3.6...4.0 / 0...0.2
Vollsignal[mA] / [V]		20...20.8 / 10.0...10.3
Reaction times		
Power-on delay time	[s]	≤ 3
Interfaces		
IO-Link Device		
Transfer type		COM2 (38.4 kBaud)
IO-Link revision		1.1
SDCI standard		IEC 61131-9 CDV
IO-Link Device ID		344 d / 00 01 58 h
Profiles		no profile
SIO mode		yes
Required master port type		A
Process data analogue		1
Process data binary		1

LR3000

LR0000B-BR34AMPKG/US

Level sensors

Min. process cycle time	[ms]	2.3
-------------------------	------	-----

Environment

Ambient temperature	[°C]	0...60
Storage temperature	[°C]	-25...80
Maximum vessel pressure	[bar]	-1...4
Protection		IP 67

Tests / approvals

EMC		IEC 60947-1
Shock resistance	DIN IEC 68-2-27:	50 g (11 ms)
Vibration resistance	DIN IEC 68-2-6:	5 g (10...2000 Hz)
MTTF	[Years]	178

Mechanical data

Process connection		G ¾ A
Materials (wetted parts)		stainless steel (303S22); probe connection: stainless steel 316L / 1.4435; PTFE; FKM; sealing: Tesnit
Housing materials		stainless steel (304S15); FKM; PBT; PC; PEI; TPE / V; PTFE
Weight	[kg]	0.388

Displays / operating elements

Display	Display unit	3 x LED green
	Switching status	1 x LED yellow
	Level	4-digit alphanumeric display
	Programming	4-digit alphanumeric display

Electrical connection

Connection	M12 connector (according to EN 61076-2-101); Gold-plated contacts
------------	---

Wiring

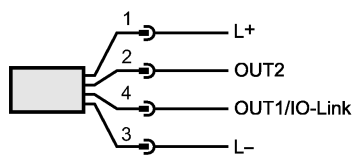

Programming of the switching outputs:

- Hno = hysteresis / NO
- Hnc = hysteresis / NC
- Fno = window / NO
- Fnc = window / NC

Accessories

Accessories (optional)	Probe, order no. E43203...E43205 / E43207...E43210; Coaxial pipe, order no. E43211...E43221, E43223, E43224; Matching accessories online next to the Datasheet → Accessories
------------------------	--

Remarks

Remarks	*) when set to oil and oil based media **) MEW = final value of the measuring range in mm; MEW = L - 30 mm
---------	---

Pack quantity	[piece]	1
---------------	---------	---