

Features

Metric	
Code No.	
513-304GT	✓
Inch	
Code No.	
513-302GT	✓

Optional Accessories

Code No.	Description	
102824	Stylus, ø1 mm ball contact (carbide)	
102825	Stylus, ø2 mm ball contact (carbide)	
102826	Stylus, ø3 mm ball contact (carbide)	

Swivel clamps, holding bars, stems and styli refer to pages F-51 to F-53 for details.

Dimensions

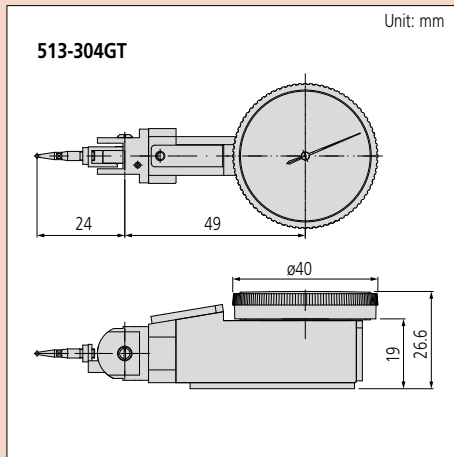

SERIES 513 – Universal Dial Test Indicator

- Universal application to all directions. (Not only the direction of the contact point, but also the direction of measurement itself can be adjusted 360 degrees without moving the indicator.)

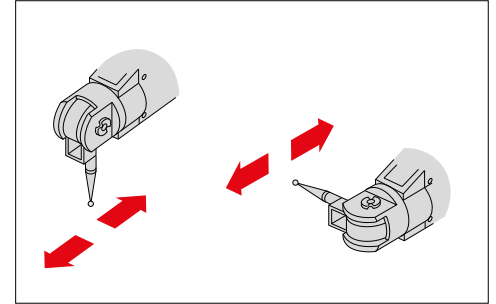

Specifications

Metric					
Code No.	Graduation	Range	Accuracy	Scale	Measuring force
Full set					
513-304GT	0.01 mm	0.8 mm	8 µm	0-40-0	0.3 N or less
Inch					
Code No.	Graduation	Range	Accuracy	Scale	Measuring force
Full set					
513-302GT	.0005"	.03"	±.0005"	0-15-0	0.3 N or less

Set Configuration: Metric

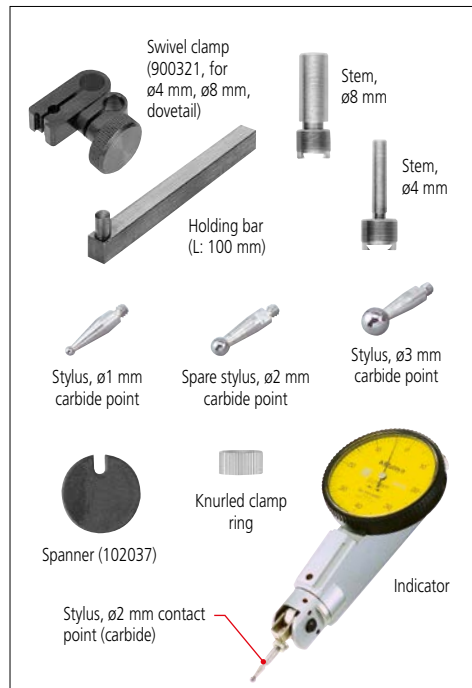

Set Configuration: Inch

